

Mini contactors B6, BC6 with 3 pole

Mini contactors from ABB are used for remotely controlling motors and other loads wherever space is at a premium. These devices feature hum free coils, shallow depth, and no limitations regarding mounting orientation.

Description

- Rated for motor loads up to 4 kW @ 400 V and 3 hp @ 480 V
- 3-pole with one built-in auxiliary contact
- Connection types: screw, soldering pin (PCB-mount) up to 12 A or flat pin (quick connect) up to 20 A
- AC or DC control voltages
- Low power consumption, hum free coils
- Acceptable use in any mounting position
- Compact design with shallow depth

Order data

B6 3-pole with screw terminal



4 kW @ 400 V AC-3
AC operated

Rated control circuit voltage V AC	Type	Order code	Packing	Weight
			unit	per pc
			pcs	kg
12	B6-30-01-14	GJL1211001R1014	10	0.175
12	B6-30-10-14	GJL1211001R1104	10	0.175
24	B6-30-01-01	GJL1211001R0011	10	0.175
24	B6-30-10-01	GJL1211001R0101	10	0.175
32	B6-30-01-18	GJL1211001R1018	10	0.175
32	B6-30-10-18	GJL1211001R1108	10	0.175
42	B6-30-01-02	GJL1211001R0012	10	0.175
42	B6-30-10-02	GJL1211001R0102	10	0.175
48	B6-30-01-03	GJL1211001R0013	10	0.175
48	B6-30-10-03	GJL1211001R0103	10	0.175
60	B6-30-01-22	GJL1211001R2012	10	0.175
60	B6-30-10-22	GJL1211001R2102	10	0.175
72	B6-30-01-23	GJL1211001R2013	10	0.175
110 ... 127	B6-30-01-84	GJL1211001R8014	10	0.175
110 ... 127	B6-30-10-84	GJL1211001R8104	10	0.175
200	B6-30-01-37	GJL1211001R3017	10	0.175
200	B6-30-10-37	GJL1211001R3107	10	0.175
220 ... 240	B6-30-01-80	GJL1211001R8010	10	0.175
220 ... 240	B6-30-10-80	GJL1211001R8100	10	0.175
380 ... 415	B6-30-01-85	GJL1211001R8015	10	0.175
380 ... 415	B6-30-10-85	GJL1211001R8105	10	0.175



BC6 3-pole with screw terminal



4 kW @ 400 V AC-3
DC operated

Rated control circuit voltage V AC	Type	Order code	Packing	Weight
			unit	per pc
			pcs	kg
6	BC6-30-01-06	GJL1213001R0016	10	0.175
6	BC6-30-10-06	GJL1213001R0106	10	0.175
12	BC6-30-01-07	GJL1213001R0017	10	0.175
12	BC6-30-10-07	GJL1213001R0107	10	0.175
20	BC6-30-10-09	GJL1213001R0109	10	0.175
24	BC6-30-01-01	GJL1213001R0011	10	0.175
24	BC6-30-10-01	GJL1213001R0101	10	0.175
30	BC6-30-01-13	GJL1213001R1013	10	0.175
30	BC6-30-10-13	GJL1213001R1103	10	0.175
42	BC6-30-01-02	GJL1213001R0012	10	0.175
42	BC6-30-10-02	GJL1213001R0102	10	0.175
48	BC6-30-01-16	GJL1213001R1016	10	0.175
48	BC6-30-10-16	GJL1213001R1106	10	0.175
60	BC6-30-01-03	GJL1213001R0013	10	0.175
60	BC6-30-10-03	GJL1213001R0103	10	0.175
72	BC6-30-01-21	GJL1213001R2101	10	0.175
75	BC6-30-01-22	GJL1213001R2012	10	0.175
110 ... 125	BC6-30-01-04	GJL1213001R0014	10	0.175
110 ... 125	BC6-30-10-04	GJL1213001R0104	10	0.175
220 ... 240	BC6-30-01-05	GJL1213001R0015	10	0.175
220 ... 240	BC6-30-10-05	GJL1213001R0105	10	0.175
250	BC6-30-10-34	GJL1213001R3104	10	0.175

B6 3-pole with soldering pin ¹⁾

4 kW @ 400 V AC-3

AC operated

Rated control circuit voltage V AC	Type	Order code	Packing unit pcs	Weight per pc kg
24	B6-30-10-P-01	GJL1211009R0101	10	0.170
24	B6-30-01-P-01	GJL1211009R0011	10	0.170
42	B6-30-10-P-02	GJL1211009R0102	10	0.170
42	B6-30-01-P-02	GJL1211009R0012	10	0.170
48	B6-30-10-P-03	GJL1211009R0103	10	0.170
48	B6-30-01-P-03	GJL1211009R0013	10	0.170
110 ... 127	B6-30-10-P-84	GJL1211009R8104	10	0.170
110 ... 127	B6-30-01-P-84	GJL1211009R8014	10	0.170
220 ... 240	B6-30-10-P-80	GJL1211009R8100	10	0.170
220 ... 240	B6-30-01-P-80	GJL1211009R8010	10	0.170
380 ... 415	B6-30-10-P-85	GJL1211009R8105	10	0.170
380 ... 415	B6-30-01-P-85	GJL1211009R8015	10	0.170

BC6 3-pole (3 N.O.) with soldering pin ¹⁾

4 kW @ 400 V AC-3

AC operated

Rated control circuit voltage V AC	Type	Order code	Packing unit pcs	Weight per pc kg
12	BC6-30-10-P-07	GJL1213009R0107	10	0.170
12	BC6-30-01-P-07	GJL1213009R0017	10	0.170
24	BC6-30-10-P-01	GJL1213009R0101	10	0.170
24	BC6-30-01-P-01	GJL1213009R0011	10	0.170
48	BC6-30-10-P-16	GJL1213009R1106	10	0.170
48	BC6-30-01-P-16	GJL1213009R1016	10	0.170
60	BC6-30-10-P-03	GJL1213009R0103	10	0.170
60	BC6-30-01-P-03	GJL1213009R0013	10	0.170
110 ... 125	BC6-30-10-P-04	GJL1213009R0104	10	0.170
110 ... 125	BC6-30-01-P-04	GJL1213009R0014	10	0.170
220 ... 240	BC6-30-10-P-05	GJL1213009R0105	10	0.170
220 ... 240	BC6-30-01-P-05	GJL1213009R0015	10	0.170

BC6 3-pole (2 N.O. + 1 N.C.) with soldering pin ¹⁾

4 kW @ 400 V AC-3

AC operated

Rated control circuit voltage V AC	Type	Order code	Packing unit pcs	Weight per pc kg
24	BC6-21-10-P-01	GJL1213109R0101	10	0.170
8	BC6-21-10-P-16	GJL1213109R1106	10	0.170
60	BC6-21-10-P-03	GJL1213109R0103	10	0.170
110 ... 125	BC6-21-10-P-04	GJL1213109R0104	10	0.170
220 ... 240	BC6-21-10-P-05	GJL1213109R0105	10	0.170

B6 3-pole with flat pin ¹⁾

4 kW @ 400 V AC-3

AC operated

Rated control circuit voltage V AC	Type	Order code	Packing unit pcs	Weight per pc kg
24	B6-30-10-F-01	GJL1211003R0101	10	0.170
24	B6-30-01-F-01	GJL1211003R0011	10	0.170
42	B6-30-10-F-02	GJL1211003R0102	10	0.170
42	B6-30-01-F-02	GJL1211003R0012	10	0.170
48	B6-30-10-F-03	GJL1211003R0103	10	0.170
48	B6-30-01-F-03	GJL1211003R0013	10	0.170
110 ... 127	B6-30-10-F-84	GJL1211003R8104	10	0.170
110 ... 127	B6-30-01-F-84	GJL1211003R8014	10	0.170
220 ... 240	B6-30-10-F-80	GJL1211003R8100	10	0.170
220 ... 240	B6-30-01-F-80	GJL1211003R8010	10	0.170
380 ... 415	B6-30-10-F-85	GJL1211003R8105	10	0.170
380 ... 415	B6-30-01-F-85	GJL1211003R8015	10	0.170

BC6 3-pole with flat pin ¹⁾

4 kW @ 400 V AC-3

DC operated

Rated control circuit voltage V DC	Type	Order code	Packing unit pcs	Weight per pc kg
12	BC6-30-10-F-07	GJL1213003R0107	10	0.170
12	BC6-30-01-F-07	GJL1213003R0017	10	0.170
24	BC6-30-10-F-01	GJL1213003R0101	10	0.170
24	BC6-30-01-F-01	GJL1213003R0011	10	0.170
48	BC6-30-10-F-16	GJL1213003R1106	10	0.170
48	BC6-30-01-F-16	GJL1213003R1016	10	0.170
60	BC6-30-01-F-03	GJL1213003R0013	10	0.170
110 ... 125	BC6-30-10-F-04	GJL1213003R0104	10	0.170
110 ... 125	BC6-30-01-F-04	GJL1213003R0014	10	0.170
220 ... 240	BC6-30-10-F-05	GJL1213003R0105	10	0.170
220 ... 240	BC6-30-01-F-05	GJL1213003R0015	10	0.170

¹⁾ Soldering pin connection acc. to DIN 40801: 0.8 x 1 mm / 0.8 x 2.54 mm
Flat pin connection acc. to DIN 46248: 1 x 6.3 mm / 1 x 2.8 mm

Functional description



- 1** Wall mounting (two diagonally arranged M4 screws)
- 2** Main terminals - 1L1, 3L2, 5L3
- 3** Auxiliary terminal - 13 NO or 21 NC
- 4** Coil terminal A1
- 5** Front extra auxiliary contact mounts
- 6** Side extra auxiliary contact mount
- 7** Coil terminal A2
- 8** Auxiliary terminal - 14 NO or 22 NC
- 9** Main terminals - 2T1, 4T2, 6T3
- 10** Mounting on DIN-rail (rear side)

Application

B6 contactors are capable of switching power circuits up to 690 V AC. They are mainly used for controlling single and three-phase motors (AC-3) and non-inductive or slightly inductive loads (AC-1). Standard versions include either 3 normally-open main poles with 1 auxiliary contact or 4 main poles in various configurations. Additional auxiliary contacts for front or side mounting are available as accessories. Mini contactors can be mounted in any position (including upside down) without derating.

Operation mode

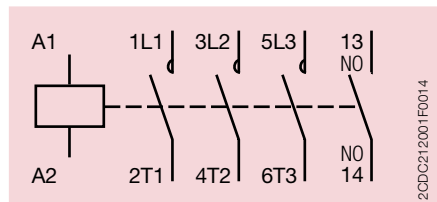

B6-30-10 / BC6-30-10

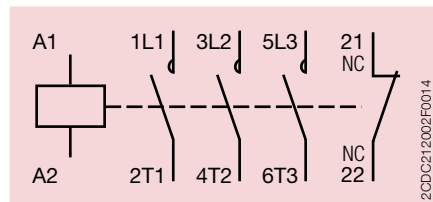

B6-30-01 / BC6-30-01

Terminal marking

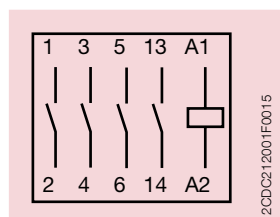

B6-30-10 ... /
BC6-30-10 ...

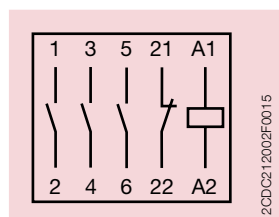

B6-30-01 ... /
BC6-30-01 ...

Dimensions

in mm and inches

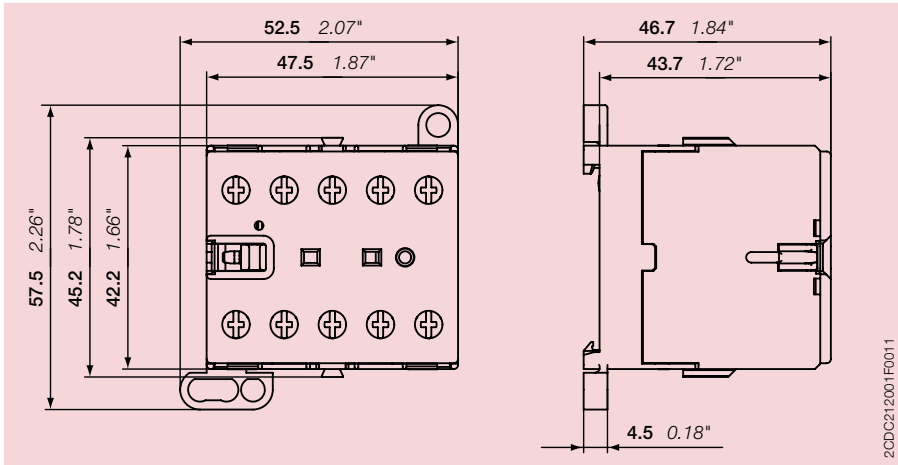

B(C)6 - Connection: Screws

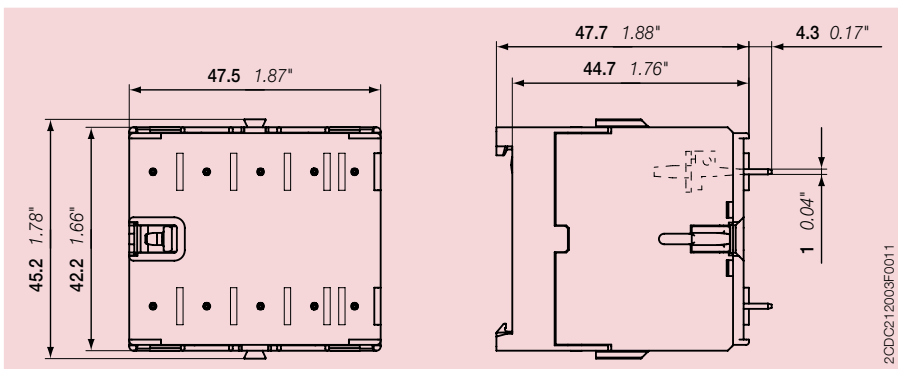

B(C)6 - Connection: Soldering pins

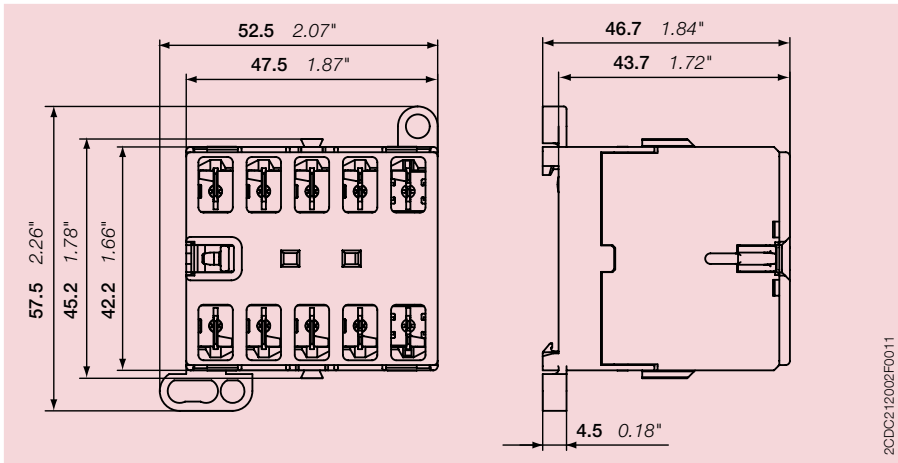

B(C)6 - Connection: Flat pin (Faston)

Technical data

Main pole – utilization characteristics according to IEC		
Standards		IEC/EN 60947-1 IEC/EN 60947-4-1 IEC/EN 60947-5-1
Rated operational voltage	main circuit	690 V AC
Rated frequency	main circuit	50 Hz, 60 Hz, DC
Conventional free-air thermal current	main circuit	20 A
Rated operational current AC-1	(220/240 V) 40 °C	20 A
	(380/440 V) 40 °C	20 A
	(500 V) 40 °C	12 A
	(690 V) 40 °C	6 A
	(220/240 V) 55 °C	16 A
	(380/440 V) 55 °C	16 A
	(500 V) 55 °C	12 A
	(690 V) 55 °C	6 A
Rated operational current AC-3	(220 V) 55 °C	8.9 A
	(230 V) 55 °C	8.5 A
	(240 V) 55 °C	8.1 A
	(380 V) 55 °C	8.9 A
	(400 V) 55 °C	8.5 A
	(440 V) 55 °C	7.4 A
	(500 V) 55 °C	6.8 A
	(690 V) 55 °C	3.8 A
Rated operational power AC-3	(220/230/240 V)	2.2 kW
	(380/400 V)	4.0 kW
	(440 V)	4.0 kW
	(500 V)	4.0 kW
	(690 V)	3.0 kW
Rated making capacity AC-3 acc. to IEC 60947-4-1		10 x I _e AC3
Rated breaking capacity AC-3 acc. to IEC 60947-4-1		8 x I _e AC3
Co-ordination with short-circuit protective devices - type 1	690 V AC - gG Type Fuses	25 A
Co-ordination with short-circuit protective devices - type 2	690 V AC - gG Type Fuses	20 A
Rated short-time withstand current	at 40 °C ambient temp, in free air, from a cold state 10 s	64 kA
Maximum electrical switching frequency	AC-1	300 cycles per hour
	AC-3	300 cycles per hour

Main pole – utilization characteristics according to UL		
Standards		UL 60947-1 UL 60947-4-1
General use rating UL/CSA	300 V AC	12 A
	600 V AC	-
Maximum motor rating UL/CSA	full load current three phase (200 V)	4.8 A
	full load current three phase (208 V)	4.6 A
	full load current three phase (220/240 V)	6.8 A
	full load current three phase (440/480 V)	4.8 A
	full load current three phase (550/600 V)	1.7 A
Horsepower rating UL/CSA	208 V AC three phase	1 hp
	220 ... 240 V AC three phase	2 hp
	440 ... 480 V AC three phase	3 hp
	550 ... 600 V AC three phase	1 hp
Maximum electrical switching frequency	AC-1	300 cycles per hour
	AC-3	300 cycles per hour

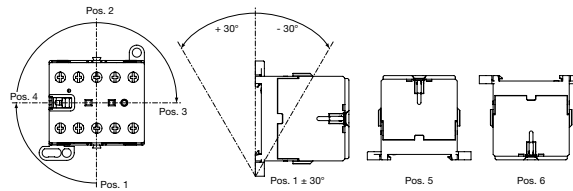
General technical data		
Rated insulation voltage		690 V
Rated insulation voltage acc. to UL/CSA		600 V
Rated impulse withstand voltage	main circuit	6 kV
Ambient air temperature	operation	-25 ... +55 °C
	storage	-40 ... +80 °C
Maximum operating altitude permissible		2000 m
Mechanical durability		10000000 cycle
Resistance to shock acc. to IEC 60068-2-27	11 ms pulse	15g
Resistance to vibrations acc. to IEC 60068-2-6		5g / 5 ... 150 Hz
Magnet system characteristics		
Coil operating limits	(acc. to IEC 60947-4-1) for AC supply	0.85 ... 1.1 x U _c (at $\theta \leq 55$)
	(acc. to IEC 60947-4-1) for DC supply	0.85 ... 1.1 x U _c (at $\theta \leq 55$)
Coil consumption	average pull-in value 50 Hz	3.5 VA
	average holding value 50 Hz	3.5 VA
	average pull-in value DC	3.5 VA
	average holding value DC	3.5 VA
Mounting characteristics and conditions for use		
Mounting position		any, position 1-6 
Mounting on DIN rail		TH35-15 (35 x 15 mm Mounting Rail) acc. to IEC 60715 TH35-7.5 (35 x 7.5 mm Mounting Rail) acc. to IEC 60715
Connection characteristics		
Degree of protection	acc. to IEC 60529, IEC 60947-1, EN 60529 main terminals	IP20
	acc. to IEC 60529, IEC 60947-1, EN 60529 auxiliary terminals	IP20
	acc. to IEC 60529, IEC 60947-1, EN 60529 coil terminals	IP20
Tightening torque	control circuit	0.8 ... 1.1 N·m
	main circuit	0.8 ... 1.1 N·m
Tightening torque UL/CSA	control circuit	7 in·lb
	main circuit	7 in·lb
Connecting capacity-main circuit UL/CSA	stranded	1/2x 22 ... 10 AWG
Connecting capacity-main circuit	flexible	1/2x 1 ... 2.5 mm ²
	flexible with ferrule	1/2x 1 ... 2.5 mm ²
	flexible with insulated ferrule	1/2x 1 ... 2.5 mm ²
	rigid	1/2x 1 ... 4 mm ²
Connecting capacity-control circuit	flexible	1/2x 1 ... 2.5 mm ²
	flexible with ferrule	1/2x 1 ... 2.5 mm ²
	flexible with insulated ferrule	1/2x 1 ... 2.5 mm ²
	rigid	1/2x 1 ... 4 mm ²
Connecting capacity-auxiliary circuit UL/CSA	stranded	1/2x 22 ... 10 AWG
Connecting capacity-auxiliary circuit	flexible	1/2x 1 ... 2.5 mm ²
	flexible with ferrule	1/2x 1 ... 2.5 mm ²
	flexible with insulated ferrule	1/2x 1 ... 2.5 mm ²
	rigid	1/2x 1 ... 4 mm ²
Wire stripping length	main circuit	9 mm

Contact us

ABB STOTZ-KONTAKT GmbH

Eppelheimer Straße 82
69123 Heidelberg, Germany
Phone: +49 (0) 6221 7 01-0
Fax: +49 (0) 6221 7 01-13 25
E-Mail: info.desto@de.abb.com

You can find the address of your
local sales organisation on the
ABB home page
<http://www.abb.com/contacts>
-> Low Voltage Products and Systems

Note:

We reserve the right to make technical changes or modify the contents of this document without prior notice. With regard to purchase orders, the agreed particulars shall prevail. ABB AG does not accept any responsibility whatsoever for potential errors or possible lack of information in this document.

We reserve all rights in this document and in the subject matter and illustrations contained therein. Any reproduction, disclosure to third parties or utilization of its contents – in whole or in parts – is forbidden without prior written consent of ABB AG.

Copyright© 2015 ABB

All rights reserved